

SMI - AIX
Single Stage Suction Centrifugal Pumps

Email sales@smipumps.co.za Tel 011 397 5672

Address 13 Patrick Road Jetpark, Boksburg, Johannesburg

SMI -AIX Single Stage Suction Centrifugal Pumps



Application

Smi -Aix series pumps are often used in airconditioning, boiler water supply, cool water circulation, fire protection sprinkling system. It carry liquids which is similar to clean water in manufacturing process area. All pumps is according to DIN24255 SPEC and is also available in Stainless steel .

Working Performance

Discharge diameter: DN32-300MM
Capacity range: 4.5-1600m³/h
Head range: 5 - 150m
Speed: 1450rpm/min & 2900rpm (50Hz Electric source)
Max speed: 3500 rpm(Electric source 60Hz motors, Impeller size will decrease)
Working Pressure : 1.6Mpa
Working Temperature : -10C - 85C

Shaft Seal

Use of Mechanical seal or Gland packing depends on customer application or choice

Type Description

EX: AIX100/40
AIX: AIX series single stage single suction centrifugal pump
100: Discharge Diameter (mm)
40: Impeller diameters
Impeller sizes can be Machined to customer requirements and needs

Part name Materials

Casing	HT250
Casing Cover	QT450-12 , SS304 , SS316
Impeller	HT250
Impeller	Bronze C95200, SS304 , SS316
Shaft	2Cr13 ,SS431
Seal Ring	Bronze C95200, SS304 , SS316
Shaft sleeve	SS304

Quick Selection Chart

2900 RPM

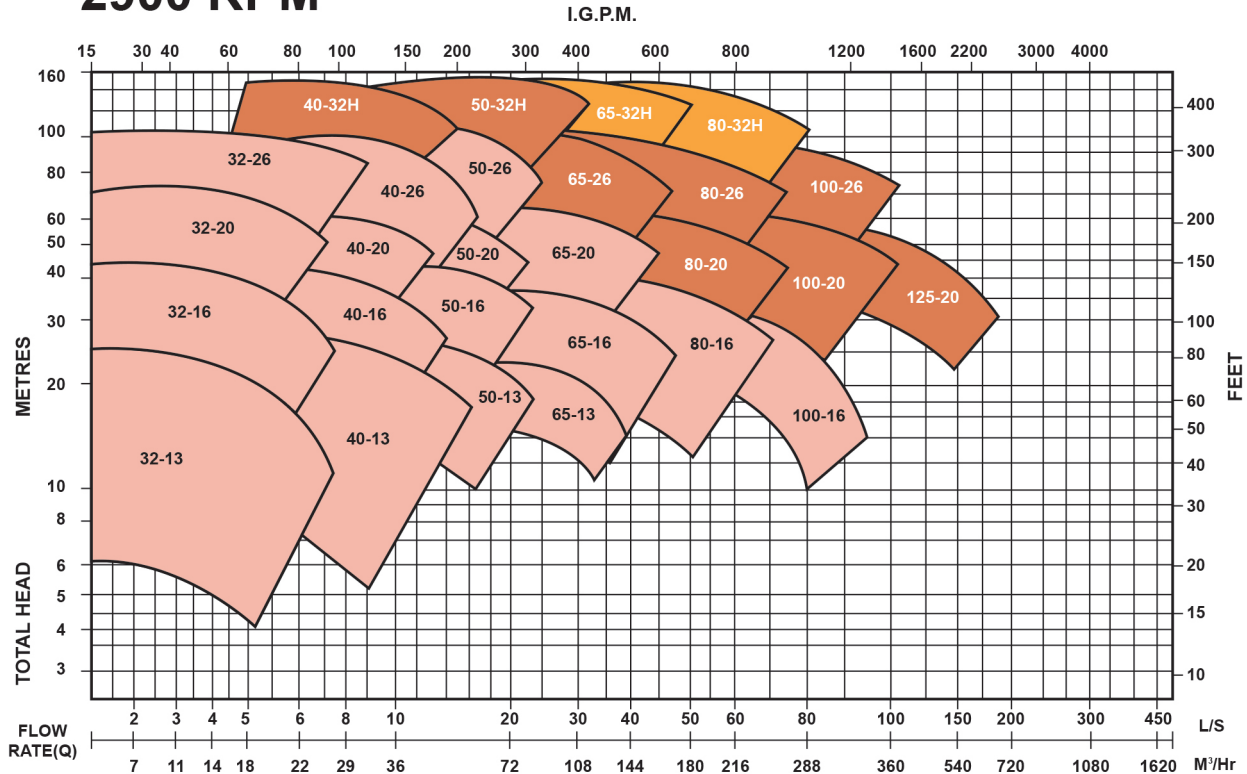

1450 RPM

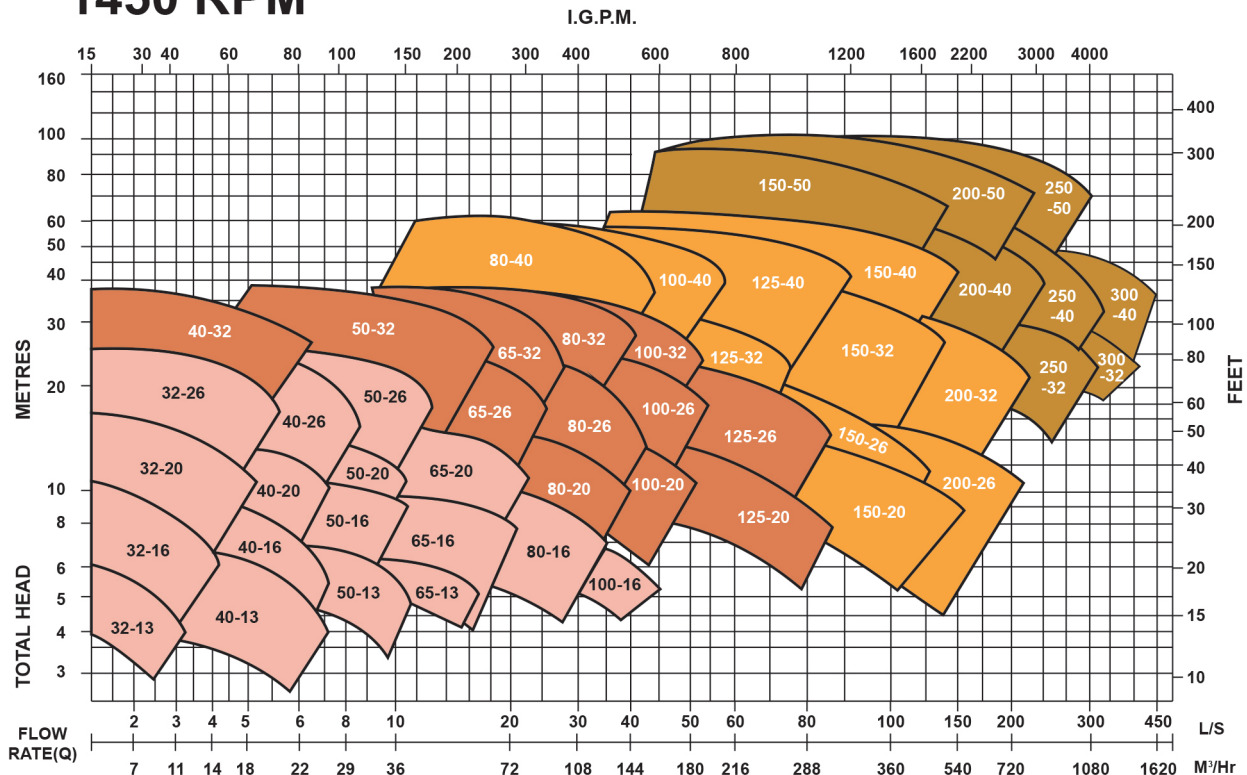

Outline Dimensions

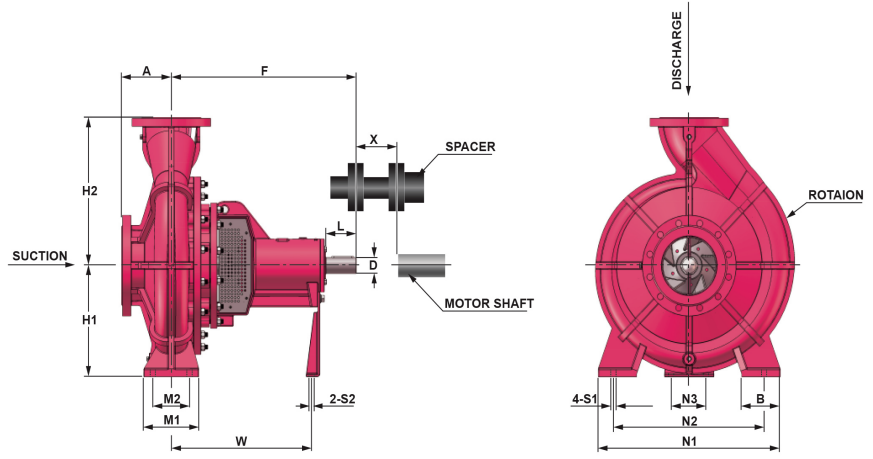

PUMP SIZE	SHAFT MODULE	SUCT.	DISCH.	PUMP				FOOT								SPACER	SHAFT END		Weight (kg)						
				A	F	H1	H2	M1	M2	N1	N2	S1	B	W	N3		S2	X		D	L				
32-13	25	50	32	80	360	112	140	100	70	190	140	Φ14	50	267	100	100	Φ24	50	30						
32-16						132	160			240	190									65					
32-20				160		180	210	160	110																
32-26				180		225	240	190		100															
40-13		65	40	80		80	112	140	100		70		210		160		Φ14			50	267	100	100	Φ24	33
40-16							132	160		240			190		65										
40-20						160	180	265	212	110															
40-26						180	225	320	250		100														
40-32H	35	125	470	200	225	125	95	345	280	65		342	140	Φ32	80	87	62								
50-13	25	65	50	100	360	132	160	100	70	240	190	Φ14	50	267	100	100	Φ24	50	40						
50-16						160	180			265	212									110					
50-20				180		225	320	250	100																
50-26				200		250	345	280		110															
50-32H	35	125	470	225	280	125	95	345	280		65	342	140	Φ32	80	87	62								
65-13	25	80	65	100	360	160	180	125	95	280	212	Φ14	50	267	100	100	Φ24	50	46						
65-16						180	225			320	250									65					
65-20				200		250	400	315	80	342	140		Φ32		80		98								
65-26				225		280	440	355												110					
65-32H	35	470	200	250	160	120	360	280	Φ18	80	342	140	Φ32	80	81	98									
80-16	25	100	80	125	360	180	225	125	95	320	250	Φ14	50	267	100	100	Φ24	50	51						
80-20	180					250	345			280	65														
80-26	35			470		200	280	160	120	400			315		Φ18		80			342	140	Φ32	80	91	103
80-32H	45			519		280	355	440	355	440	355		Φ18		80		362			140	Φ42	110	141	103	
80-40	45	519	280	355	440	355	440	355	Φ18	80	362	140	Φ42	110	141	103									
100-16	25	125	100	140	360	180	225	125	95	320	250	Φ14	50	267	100	100	Φ24	50	63						
100-20	200					280	400			315	80									342	140	Φ32	80	94	
100-26	35			470		225	280	160	120	440			355		Φ18		80								342
100-32	45			530		280	355	440	355	500	400		Φ23		100		370			140	Φ42	110	164	110	
100-40	45	530	280	355	440	355	500	400	Φ23	100	370	140	Φ42	110	164	110									
125-20	35	150	125	140	470	250	315	160	120	400	315	Φ18	80	342	100	140	Φ32	80	110						
125-26	35					280	355			400	315									80	342	140	Φ32	110	158
125-32	45			530		280	355	400	315	500	400		Φ23		100		367								
125-40	45			530		280	355	400	315	500	400		Φ23		100		367			140	Φ32	80	154	178	
150-20	35G	200	150	160	495	280	400	200	150	550	450	Φ23	140	511	140	180	Φ55	110	393						
150-26	45					250	355			450	350									80	370	110	Φ42	110	144
150-32	60			530		280	400	315	455	200	150		550		450		Φ23								
150-40	60			530		280	400	315	455	200	150		550		450		Φ23			140	511	140	Φ42	110	183
150-50	60	250	200	180	670	375	500	300	240	720	600	Φ27	160	520	140	180	Φ65	140	468						
200-26	45					280	400			550	450									80	389	100	511	140	Φ42
200-32	55			200		670	355	450	550	450	550		450		Φ23		100								
200-40	55			210		760	400	500	300	240	720		600		Φ27		160			520	140	Φ65	140	341	
200-50	70	210	760	400	500	300	240	720	600	Φ27	160	520	140	Φ65	140	341									
250-32	60	300	250	200	670	355	525	250	175	600	500	Φ23	100	511	140	180	Φ55	110	368						
250-40	70					250	780			400	500									250	710	500	Φ23	120	540
250-50	70			240		873	425	545	300	240	720		600		Φ27		165			632	140	Φ65	140	465	
300-32	75			259		875	403	562	300	240	720		600		Φ27		140			634	140	Φ70	147	520	
300-40	75	280	875	500	600	300	240	720	600	Φ27	150	626	140	Φ70	147	583									

Pump Structures

